

SERVICE MANUAL

ACCESSORY CONTROLLER (HAC)



Introduction

Overview



Abbreviations

The following abbreviations and illustrations are used in the following sections.

Term	Explanation
HAC	H ome-ventilation A ccessory C ontroller module
USB	Universal serial bus - connect to computers
GTC	Geothermal brine based ground heat collector
Ele	Electrical
PH	Pre-heater
NO	contact set that normally open, when not active
NC	contact set normally closed, when not active

Illustrations used

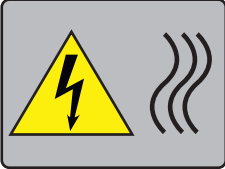
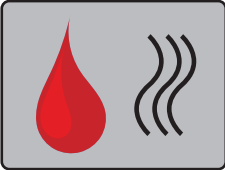
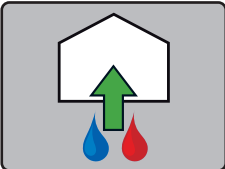
The following illustrations are used:

Illustration	Description
	Electrical heater
	Water based heater
	Geothermal pre-heater/cooler
	External temperature sensor

Manual	Part number of this service manual is 086442. The manual covers installing and setting any factory supplied accessory to the Accessory Controller (HAC).
Target group	The target group for this service manual are the technicians who install and setup the HAC.
Copyright	Copying of this service manual, or part of it, is forbidden without prior written permission.
Reservations	The supplier reserves the right to make changes and improvements to the product and the service manual at any time without prior notice or obligation.
Table of contents	This service manual covers the following main topics:

Introduction	2
Overview	2
Product description	4
Overall description	4
Technical data	6
Connection and setup	7
Connecting external accessories.....	8
Duct mounted accessories.....	8
Electrical preheater.....	9
Afterheater	11
Geothermal collector kit.....	14
Damper actuators	15
Alternating inputs	17
CO ₂ sensor analog input.....	19
Alarms.....	21
Appendix	22
Overall schematic	22

Product description



Overall description

Introduction

The Accessory controller is used as an extension module to the residential ventilation products. It is able to control a wide variety of external accessories. This section describes the overall product, and its functionality.

HAC versions

This manual covers two main versions.

Model	Description	Fitted with Plug
HAC 1	Accessory controller with: <ul style="list-style-type: none"> • 3 m cable • daisy chain option for more MODBUS items • Preheat option available 	 ECH350V 6 pin screw terminals plug
HAC 2	Accessory controller with: <ul style="list-style-type: none"> • 3 m cable • NO daisy chain option • NO preheat option 	 6P6C connector (RJ 12)

Compatibility chart Please use below list, to find correct match of components/software:

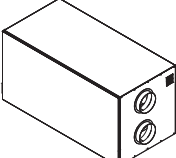
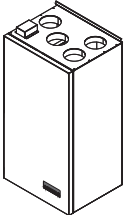
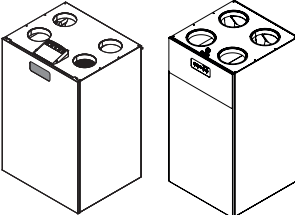
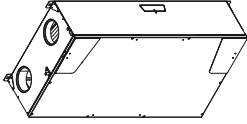
HAC	Ventilation unit	Unit sw	HAC sw	After-heat sensor type	Pre-heat available
HAC 1	 Horizontal with external controller	all	300	TG-K300	Yes
		all	301	TG-K360	
	 Vertical with controller placed low on front plate	all	300	TG-K300	
		all	301	TG-K360	
HAC 2	 Vertical with controller placed high on front plate	all	300	TG-K300	Yes. Not controlled by HAC 2.
		all	301	TG-K360	
	 Under ceiling unit	all	300	TG-K300	
		all	301	TG-K360	

Product description: Overall description

Software update The software of the module, can be updated. Contact your installer if you need to update your software.

Overall functionality The below shows in block schematics the in/outputs and there functions:

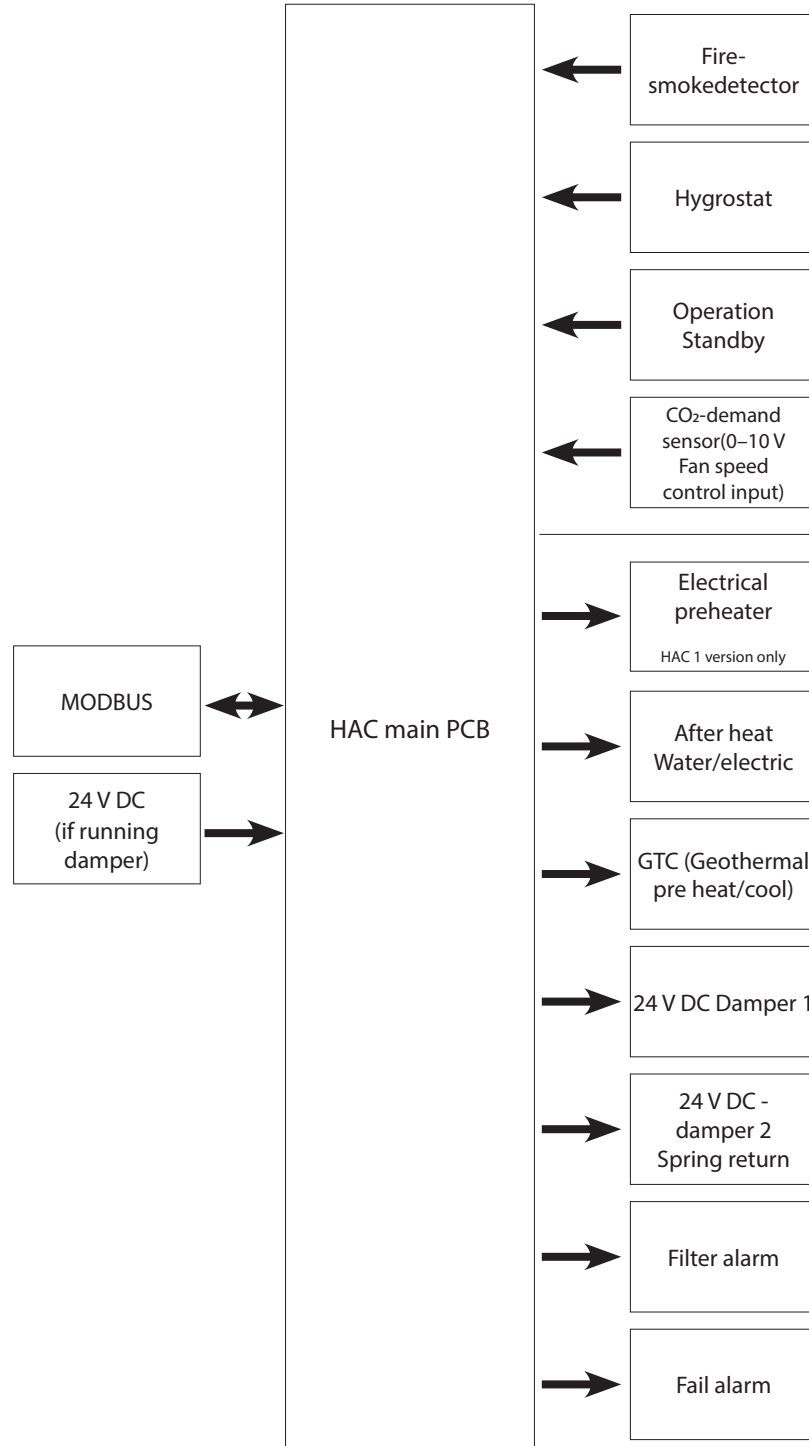

Fig. 1

Technical data

Specification

The HAC has the following technical data

Specification	Data
Power Supply	DC 12V±5%
Display	Different colour of LED: Green = OK Orange = Active Red = Fault
Temperature range, operation	-20 to +50 °C
Temperature range, storage	-40 to +70 °C
Humidity	RH max 95%, non condensing
Encapsulation	IP66 (6 Pin connector not include)
Dimensions	170x140x95mm
Weight	1050g

Temp Sensor specification

Connections marked T1GTC, T2AH and T2AC (air temperature) inputs are compatible with Regin TG-K300 / TG-K360 sensor. Select appropriate sensor according to the "Compatibility chart" on page 4 and contact your installer, if you need to update the software.

Connections marked TFAH (frost protection) input is compatible to the Regin TG-A130 sensor.

This below table shows the specification of temperature sensors:

Type	10 KΩ	12,5 KΩ	15 KΩ	Usage
TG-K300	+30 C°	0 C°	-30 C°	Air temperature
TG-K360	+60°C	+30 C°	0 C°	Air temperature
TG-K330	+30 C°	+15 C°	0 C°	Air temperature
TG-A130	+30 C°	+15 C°	0 C°	Frost protection

Warning: Sensor TG-K330 delivered with internal thermostat controlled heaters, cannot replace any other of the above listed sensors.

Connection and setup

Screw terminal plug version



The HAC version with green screw terminal plugs factory fitted, can be used for a wide variety of home ventilation systems.

The HAC will be powered over MODBUS from the ventilation unit.

Follow this step by step to connect HAC to unit:

Step	Action
1	Disconnect power to the ventilation unit
2	Please locate the 6 pin green socket on the ventilation unit. Location is on top or right hand side of the units enclosure.
3	Is this socket occupied by other MODBUS controls, please disconnect.
4	Plug the HAC controller into the ventilation MODBUS socket, and reconnect any other MODBUS control if it was present in step 3
5:	Reconnect power to the ventilation unit, and confirm green "status ok" LED on the PCB, inside the HAC, as the HAC is powered through the MODBUS.

If an external damper or motorized valve needs to be connected, an external power supply needs to be connected as well. See separate sections for more information about additional supplies

6P6C Connector (RJ 12)



The HAC version with a 6P6C plug, is to be connected directly to the empty socket onto the unit. The HAC will be powered over MODBUS from the ventilation unit.

Follow this step by step to connect HAC to unit:

Step	Action
1	Disconnect power to the ventilation unit
2	Locate the RJ socket on the ventilation unit.
3	Plug the HAC controller into the ventilation MODBUS socket
4	Reconnect power to the ventilation unit, and confirm green "status ok" LED on the PCB, inside the HAC, as the HAC is powered through the MODBUS.

If an external damper or motorized valve needs to be connected, an external power supply needs to be connected as well. See separate sections for more information about additional supplies

IMPORTANT

IMPORTANT: this version CANNOT control external electrical pre-heaters.

Please use internal electrical pre-heater instead.

Data protocol

Selected versions of the HAC module have additional MODBUS connection, as well as an additional internal data connection.

For security reasons, none of these are to be connected to other external equipment, and no register protocol tables are available.

Remote control

Many of the control functions have options, that only can be controlled by the remote control, designed to the ventilation unit. Have at least a remote control available, when connecting and setting the accessories to the HAC

HAC failure alarm

The general strategy of the LED for each connector is:

Green = OK
 Orange = Active
 Red = Fault

The red Fail LED in the Status field is looking after correct termination of some of the equipment. I.e. it will be red if both "electrical preheating switch" is turned on and "GTC sensor" is connected at the same time, because this is not allowed.

Connecting external accessories

Duct mounted accessories

Introduction

Important : when implementing coolers or heaters in ducts, please follow the correct order.

Placement

In order for the software in the HAC as well as the ventilation unit to work correctly, its mandatory to follow the below shown placement order, if more heaters/cooler are mounted in the same system.

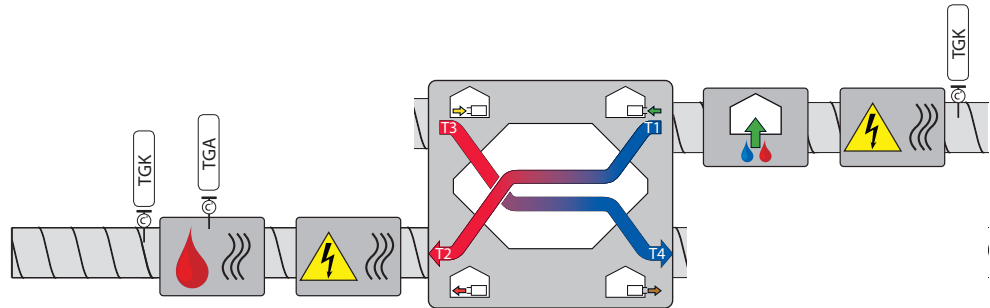

Fig. 2

Please see each separate sections for instructions on how to install each part

Electrical preheater

IMPORTANT

IMPORTANT: only versions with 6 pins screw terminal plugs can control pre-heaters.

Introduction

Electrical preheater is typically used to preheat the outside air in cold geographic areas in order to keep the ventilation unit in operation all year for the pleasure of the occupants and the home

Connection

Connect cables according schematic, to connect the 0-10V DC controlled pre-heater.

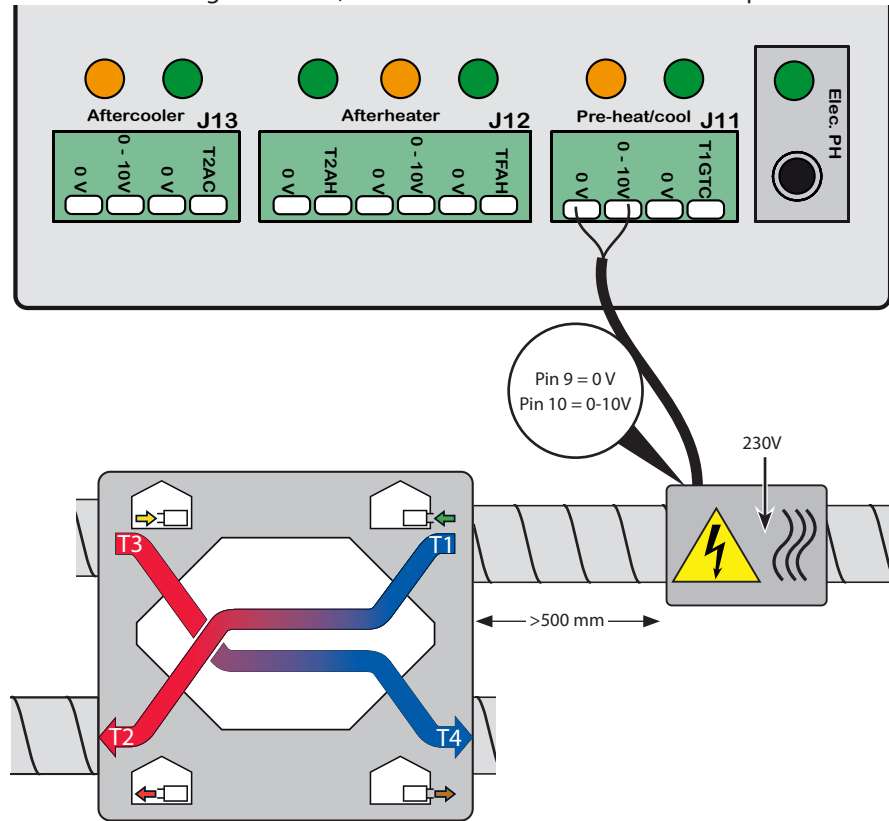

Fig. 3

Select electrical

In order for the HAC to know that this is an electrical heater, and no temperature sensor is present, press and hold the micro switch in the corner of the pcb, named "Elec.PH" for 5 seconds until the LED is lit

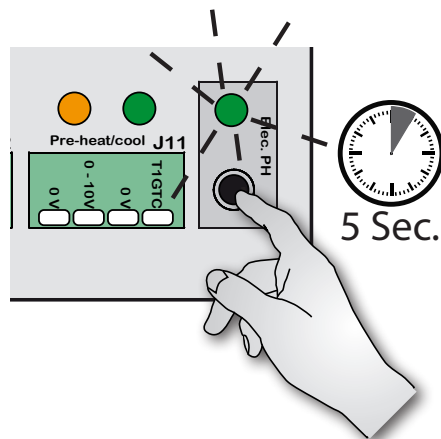

Fig. 4

Check functionality When the pre-heater is switched on, a heat symbol will show in the T1 air path

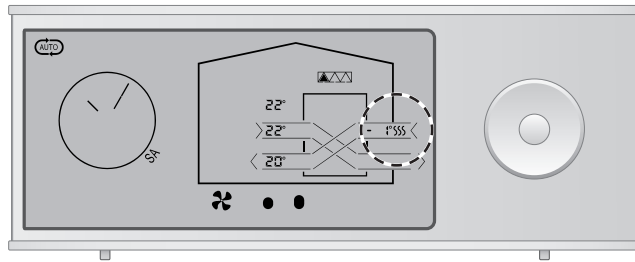

Fig. 5

Settings

The preheater will switch on/off automatically, when needed.
The preheater setpoint can be adjusted between 0° and -10°C, or be disabled.

Step	Action
1	Press the RIGHT button for 10 sec., until the installer menu is activated (the icon for the ventilation unit is flashing)
2	Press the RIGHT button till the preheater icon in the outdoor air duct (T1) flashes slowly.
3	Press the CENTER button and the preheater icon flashes quickly together with the previously preheater setpoint (T1/SET PH).
4	Press UP/DOWN to change the preheater setpoint and confirm by pressing CENTER. If the setpoint is "OF" the preheating will always be switched off.
5	Press RIGHT for 10 sec. until the installer menu is closed. (the icon for the ventilation unit stops flashing)

If GTC (geothermal collector) is connected, it will be permanently set to heat if the outside temperature (T1) < 0°C

Afterheater

Introduction

The HAC can control both an electrical and a water based afterheater. The heater will increase the supply temperature for comfort, and will add additional heating to the house. Select appropriate sensor according "Compatibility chart" on page 4

Connection ELECTRICAL afterheater

Connect cables according schematic, to connect a 0-10V DC controlled after heater.

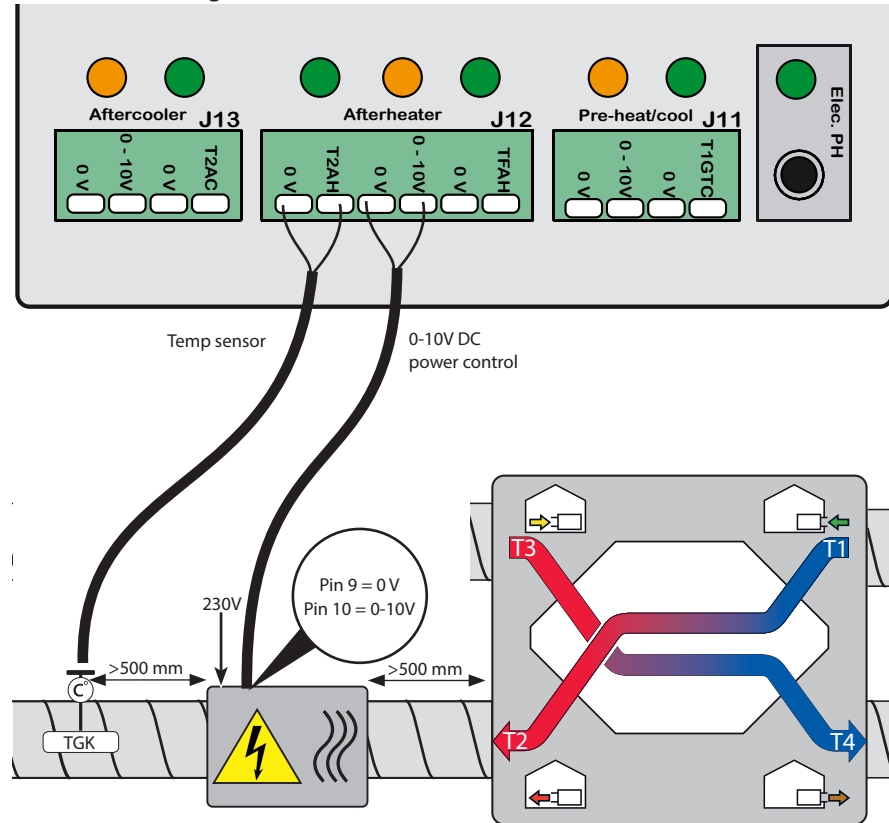

Fig. 6

Connect cables according schematic, to connect a water based after heater kit.

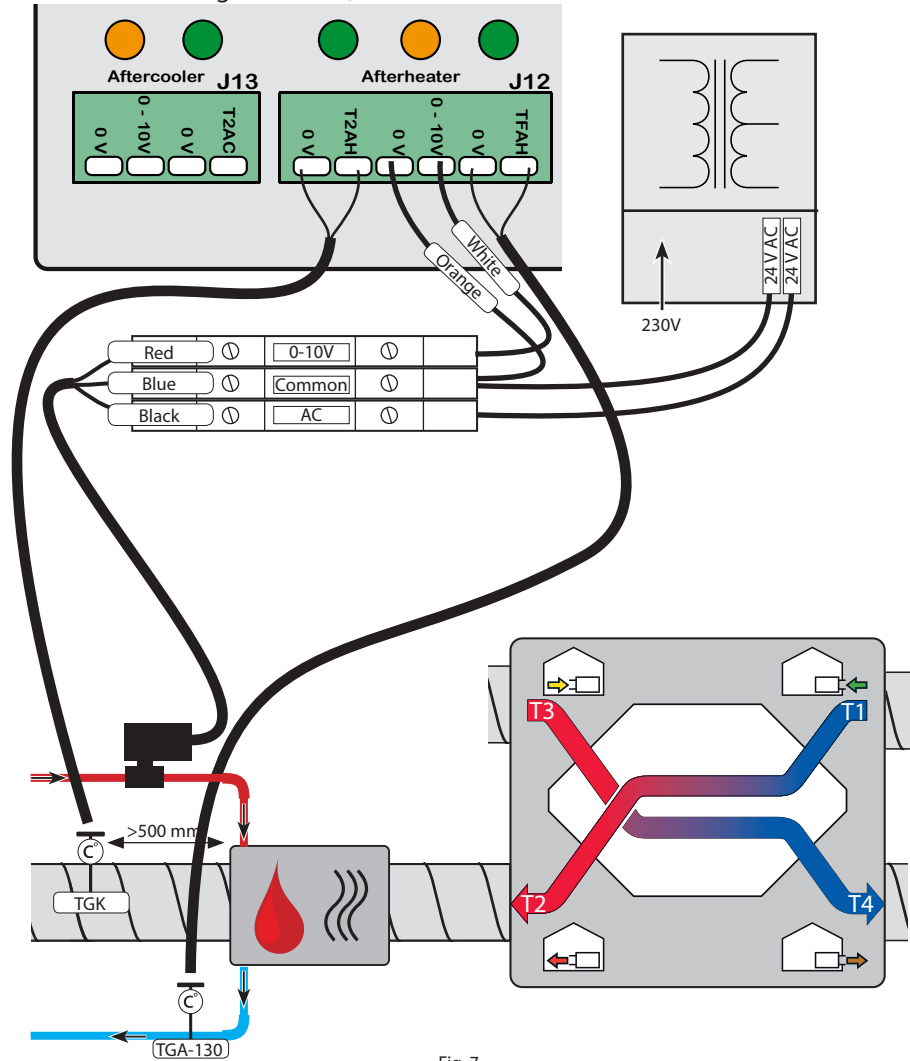

Fig. 7

Check functionality When the after heater is switched on, a heat symbol will be shown in the T2 air path

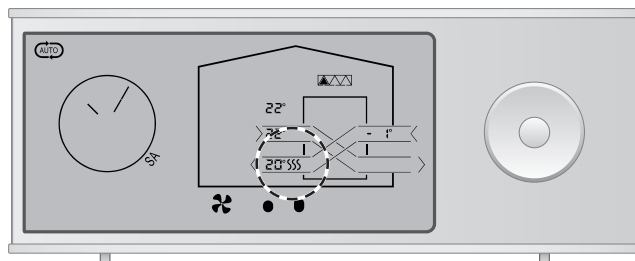

Fig. 8

Temperature controls

The afterheater will switch on/off automatically, when needed. Preconditions for the after heater to operate is that bypass must not be active. This means that after heating cannot be activated when outdoor temperature (T1) is $\geq 15^{\circ}\text{C}$ or extract temperature (T3) is $\geq 24^{\circ}\text{C}$ (These setpoints are adjustable with remote control or PC tool)

The temperature setpoint can be adjusted in accordance with one or more of the following 3 principles:

Option	Setting
Afterheating for comfort supply air	If afterheating is only required to prevent supply of cold air or draught inconvenience, the T2 supply air temperature can be used as setpoint and regulation temperature. (Factory setting +18°C)
Afterheating for heating of the house	If afterheating is used as primary heat source for the whole house, T3 extract air temperature can be used as setpoint and regulation temperature. (Factory setting = OF, meaning that heating is not regulated after this setpoint)
Afterheating for heating of the house or rooms	If afterheating is used as primary heat source for the whole house and/or specific rooms, T5 temperature measured in the remote control can be used as regulating temperature in the room where it is placed. (More re-remote controls can be connected) (Factory setting = OF, meaning that heating is not regulated after this setpoint)

If all three afterheater setpoints are "OF" the afterheater is OFF.

Setpoint location

This illustration shows the location of the three temperature setpoints described above

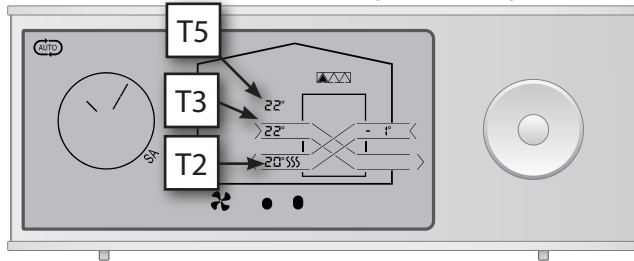

Fig. 9

Change setpoint

Follow this below procedure to change any one of the setpoint

Step	Action
1	Activate the menu line by pressing CENTER
2	Press RIGHT to navigate to afterheater icon. The afterheater icon flashes slowly (30/min). Simultaneously T2, T3 and T5 continue to show the real temperatures in the unit.
3	Press CENTER to navigate to the AFTERHEATER menu. The display shows the latest settings of all three setpoints (T2, T3, T5) on their respective places. OFF means that the afterheater is not controlled in accordance with this setpoint.
4	Press CENTER. The afterheater setpoint for T2 flashes quickly (120/min), and the afterheater icon flashes.
5	Press UP/DOWN to set the afterheater setpoint T2, and confirm by pressing CENTER.
6	T3 afterheater setpoint now flashes quickly (120/min) and the afterheater icon flashes. Press UP/DOWN to set the afterheater setpoint T3, and confirm by pressing CENTER.
7	T5 afterheater setpoint now flashes quickly (120/min) and the afterheater icon flashes. Press UP/DOWN to set the afterheater setpoint T5, and confirm by pressing CENTER.
8	The afterheater setpoints are now set and the afterheater icon on the display flashes slowly (30/min) and all temperatures on the display are again real measurements in the unit.
9	Press CENTER for 3 seconds to leave the menu.

If all three afterheater setpoints are "OF" the afterheater is OFF.

Geothermal collector kit

Introduction

GTC (geothermal collector), is based on geothermal heat or any other source that can provide constant water temperature between 0 °C. to +8°C.

If GTC is connected, it will be permanently set to pre-heat on a fixed value, determined by the unit software. Select appropriate sensor according “compatibility chart”

Likewise it is set to cool whenever the conditions for bypass-cooling are fulfilled.

Connect Geothermal kit

Please follow below schematics, to connect a geothermal collector kit

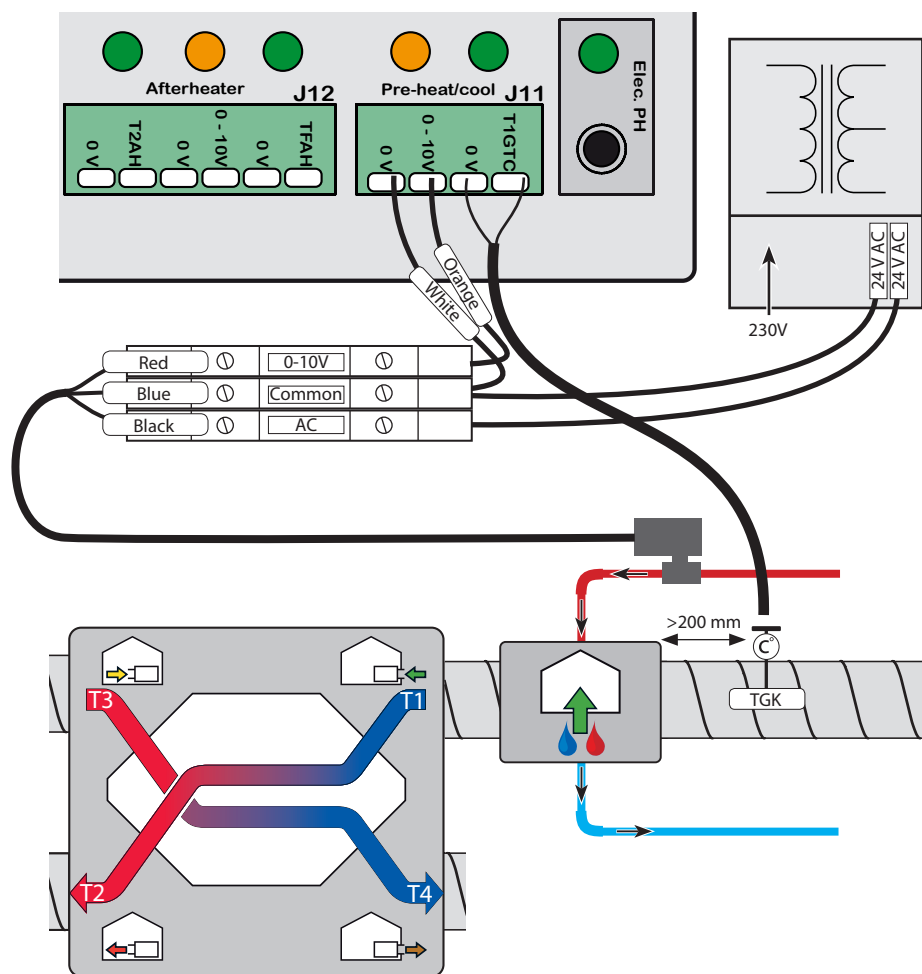

Fig. 10

Operation of geothermal collector

Pre-heat.

When GTC is connected, it will be permanently set to activate preheat on a fixed temperature that's controlled by the unit software.

Pre-cooling.

When GTC is installed, it is enabled/disabled by the same setpoints and control strategy as the built-in BYPASS-COOLING function, and bypass are always switched on at the same time. Please see appropriate remote control manual for BYPASS-COOLING settings.

If the BYPASS-COOLING is automatically disabled due to high outside temperature, GTC will still be enabled.

Damper actuators

Introduction

The HAC controller is prepared for operation of 24V DC damper motors. The system can control both spring return (e.g. Belimo TF24) damper motors and direction controlled (e.g. Belimo LM 24) damper motors.

IMPORTANT: In both cases, additional DC power for the damper motors, must be delivered by an external 24 VDC power supply.

Whenever there is power to the system all dampers are open unless:

- Standby switch is activated (J8)
- Fan speed 0 is selected due to any reason for longer/shorter time
- Fire thermostat is activated (open circuit)

Connect a DIRECT CONTROLLED motor (3 wires)

Follow the below schematic to connect one or more direct controlled damper motor. The output can handle a maximum of 100 mA current, and is over current protected with a self-resetting fuse.

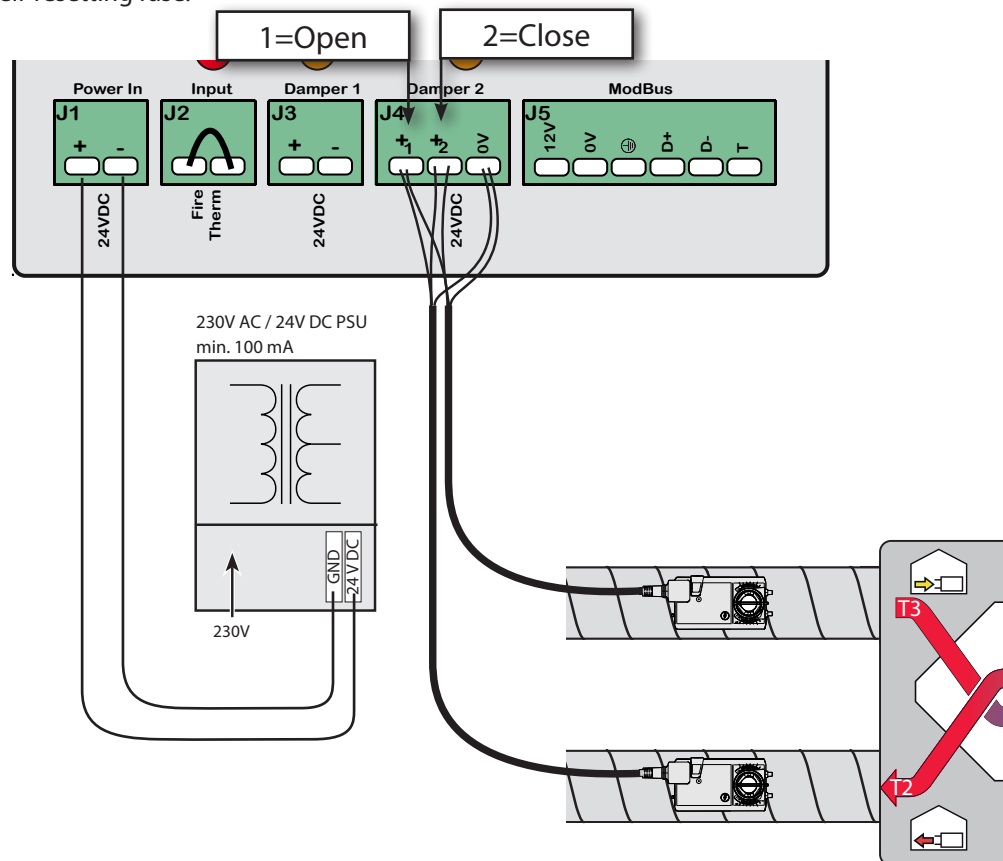

Fig. 11

Connect a SPRING RETURN MOTOR (2 wires)

Follow the below schematic to connect one or more spring return damper motor. This type will open if powered, and closed again when power is disconnected. The output can handle a maximum of 300 mA current, and is over current protected with a self-resetting fuse.

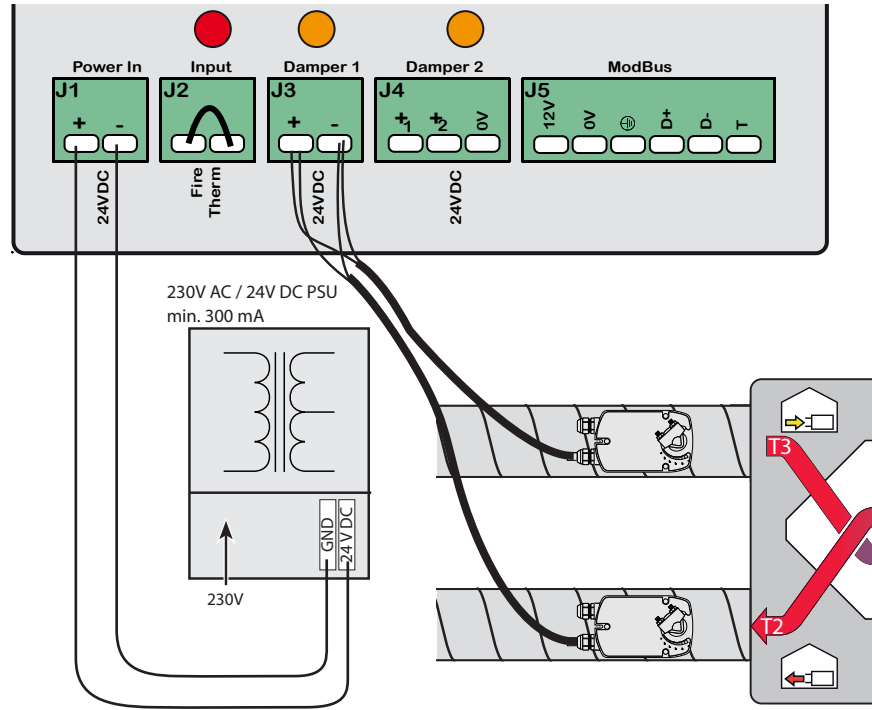

Fig. 12

Alternating inputs

Fire thermostat

In case fire protection system is desired it is possible to connect fire thermostat(s) to the system on terminal J2. It can be recommended in combination with damper solutions. (see section damper control)

The Fire thermostat is fitted with a jumper wire from factory. The +24VDC from J1 (damper 24VDC input) is routed through this jumper, and direct to damper 1 output (spring return TF24). This ensures immediate damper shut down, if fire burns down the HAC controller.

Fire alarms are signalled to the ventilation unit that shuts down as well, and can only be reset by re-booting the ventilation unit. No user interaction applies.

Connect with a NO (normally open) relay as shown. Power on the relay coil makes the relay active, and no fire input. If this circuit is broken due to fire OR smoke detector removes the power from the coil, the input will disconnect, and in any case close the dampers, and stop the unit

The fire thermostat carries a maximum of 24V DC / 300 mA.

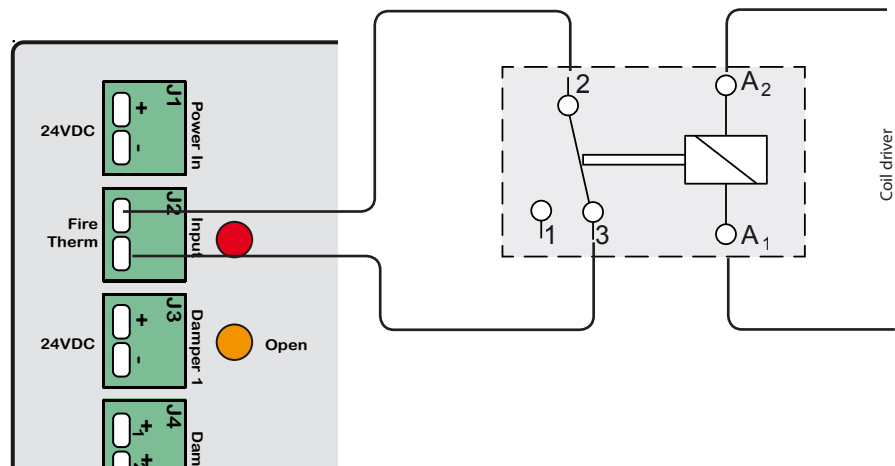

Fig. 13

Standby switch

The unit can be set to standby mode using closed contact on J8. The unit will stay in standby mode until the contact is open again.

CAUTION: It is only allowed to stop the ventilation unit for 4 hours, unless dampers are installed to avoid drafting air which can cause condense problems and cold draft issues. The supplier cannot be held responsible for any unwanted usage of this input.

The input will sink a maximum of 12V DC/ 1 mA

Connection:

- Connect a potential free normally open (NO) switch to connector J8, between pin 3 and pin 4.
- When the switch is active, the ventilation unit is stopped.
- When the switch is released, the ventilation unit resumes previous operation.

No user interaction applies

Alternative connect an OC output circuit (Open Collector) that can sink minimum 1 mA

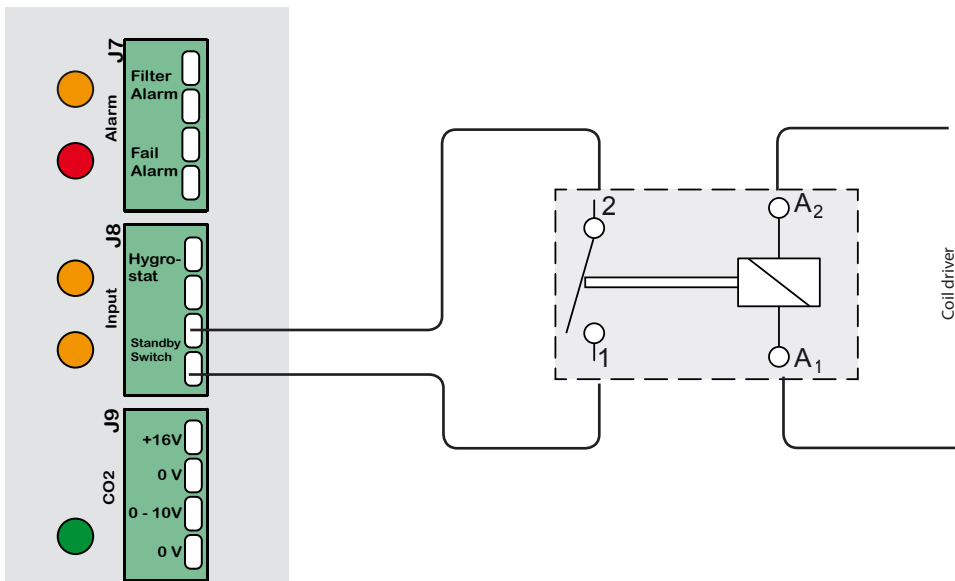

Fig. 14

Humidistat

If an external on/off humidistat is connected to the system the ventilation unit will speed up to fans speed 3 whenever the RH% of the external humidistat setpoint is exceeded. Connect a humidistat with normally open (NO), potential free contacts, to connector J8 between pin 1 and pin 2.

Alternative connect an thermostat with OC output circuit (Open Collector) that can sink minimum 1 mA

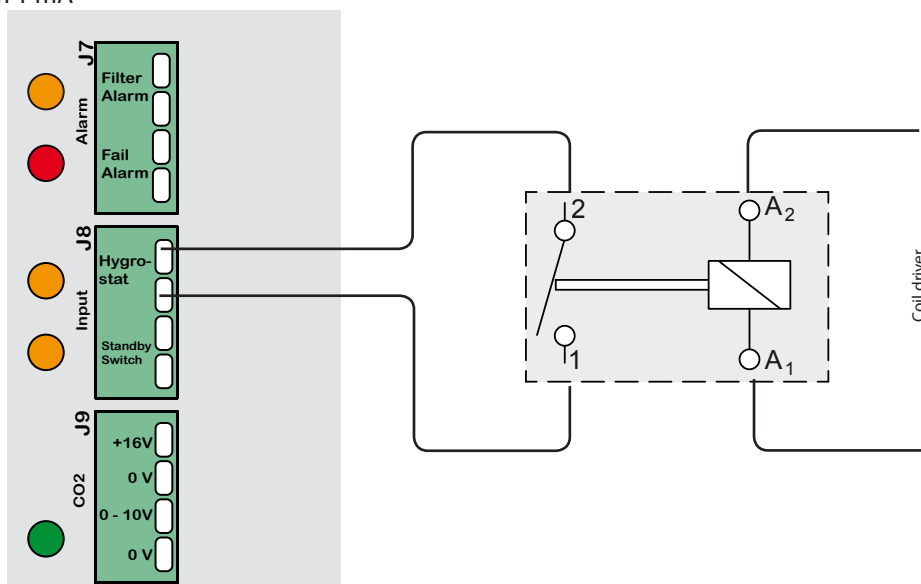

Fig. 15

RH% display

The RH% digit value shown is always the internal sensor if any. The drop will be "FULL" if any external humidity sensor is overruling the internal.

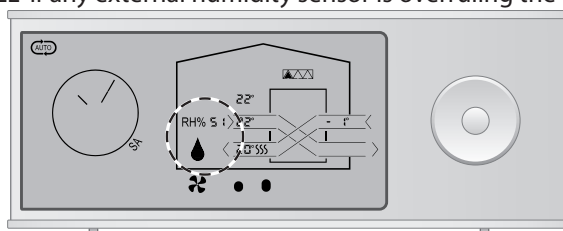

Fig. 16

CO₂ sensor analog input

CO₂ sensor

If a CO₂-sensor is connected and the unit is set to AUTO mode the airflow is controlled by the CO₂-concentration in the room where the CO₂-sensor is placed.

Connect the CO₂ sensor to connector J9

Pin 1: +16V DC / 100mA power

Pin 2: Gnd

Pin 3: 0-10V DC input

Pin 4: Gnd

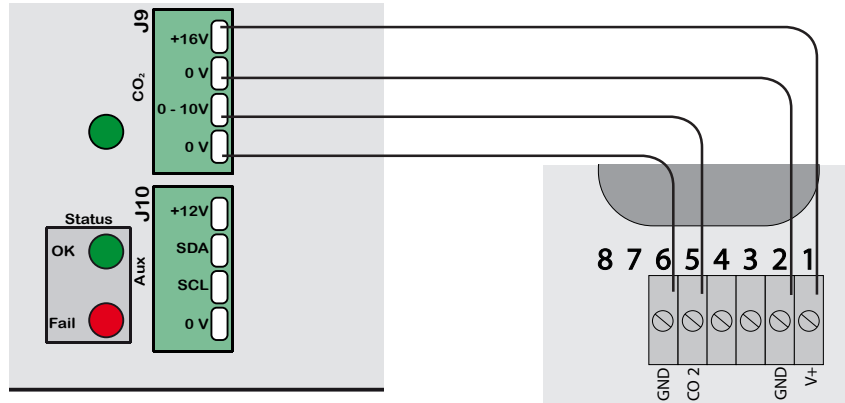

Fig. 17

External fan control The CO₂ sensor input can also be used for direct fan speed control, from external BMS systems, like KNX, LON, IHC, Smarthouse, Lutron etc.

All of these systems has in general a 0-10V DC output DIN rail module, intended to be used for dimming fluorescent lamps, by controlling the internal ballast controllers.

Connect a DIN rail module 0-10V output (compatible with your type BMS) to the CO₂ input and control the fan speed according the below diagram.

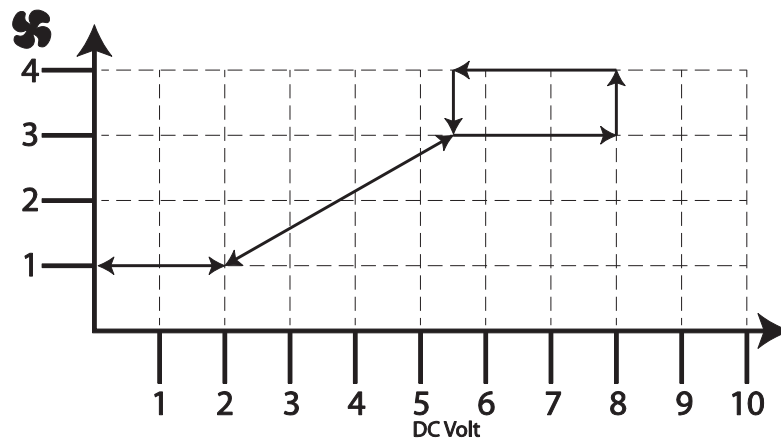

Fig. 18

As the fan control is softly accelerating/decelerating, it is recommended to apply "Scenes" in BMS programming on the 0-10V DC module, in which the light amount is set in %, when changing fan speed.

If the unit is fitted with another demand sensor, this could keep the fan in another speed if the demand is higher.

CO₂ level display

When any external CO₂ is detected, the cloud and corresponding digit will be shown in the display of the remote displays

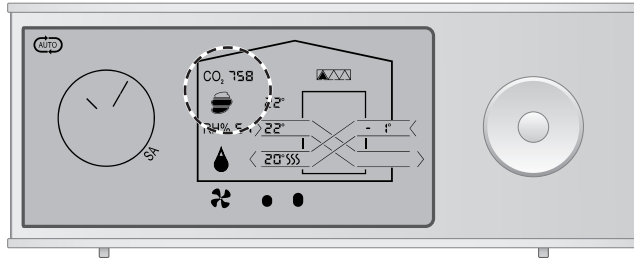

Fig. 19

Alarms

Alarm signalling

A general operation alarm as well as a Filter alarm output, can be connected to terminal J7. The output is dry contacts (relay) max. 24VDC, 3 Amp. Normally open (NO). In case of power OFF both general and filter alarm is closed

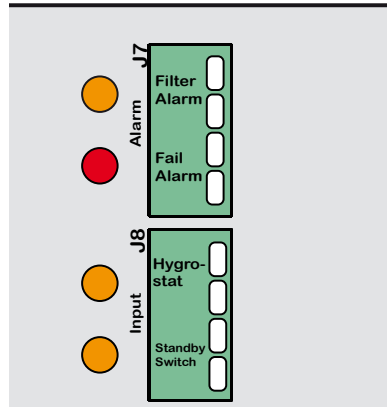
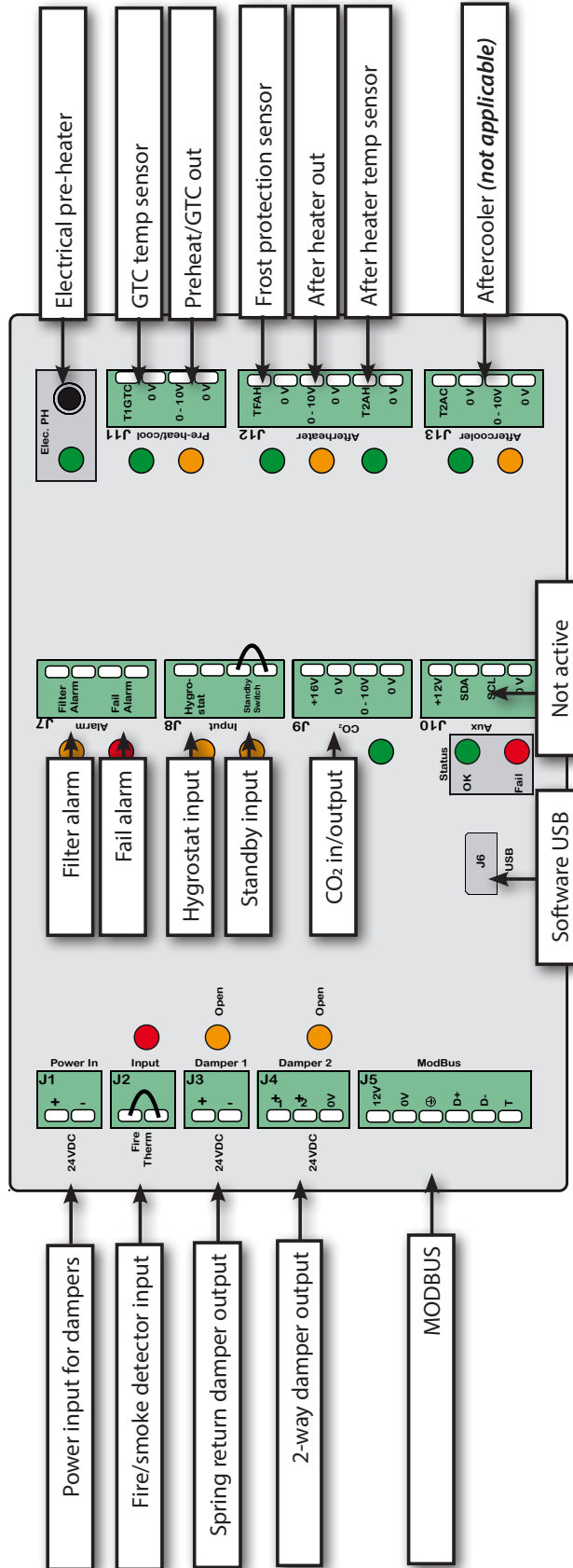

Fig. 20

Appendix

Overall schematic

This shows all connections in block schematics





086442

Dantherm can accept no responsibility for possible errors and changes (en)

Der tages forbehold for trykfejl og ændringer (da)

Irrtümer und Änderungen vorbehalten (de)

Dantherm n'assume aucune responsabilité pour erreurs et modifications éventuelles (fr)

